

Variant 3.3V of LCD-VLGEM1277-01-Temp1

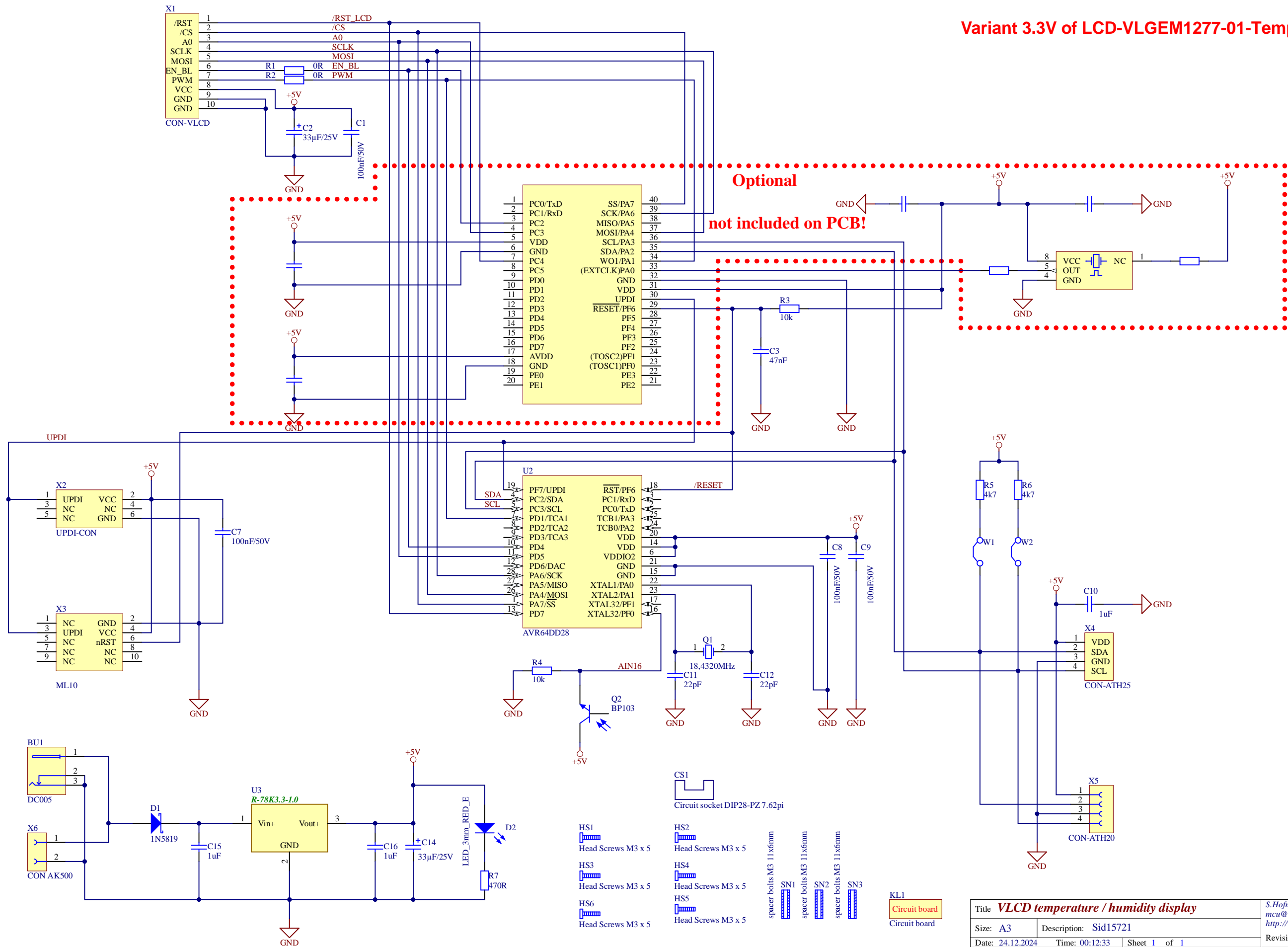

**Optional
not included on PCB!**

- HS1 Head Screws M3 x 5
- HS2 Head Screws M3 x 5
- HS3 Head Screws M3 x 5
- HS4 Head Screws M3 x 5
- HS5 Head Screws M3 x 5
- HS6 Head Screws M3 x 5
- SN1 spacer bolts M3 11x6mm
- SN2 spacer bolts M3 11x6mm
- SN3 spacer bolts M3 11x6mm
- KL1 Circuit board

